



英格爾科技股份有限公司

ENG ELECTRIC CO., LTD.

Revision: 02

Approval Sheet

CUSTOMER: WW73

CUSTOMER MODEL NO.: _____

ENG MODEL NO.: 3A-242WU24

ENG PART NO.: @3A-242WU24-020

DESCRIPTION: Switching Power Supply

DATE: 2009/10/22

PREPARED	DESIGNED	CHECKED	APPROVED

APPROVAL DATE:

CUSTOMER APPROVAL		

總部：台灣桃園縣龜山鄉民生北路 1段536號5樓

Head Office: 5F,NO.536, Sec.1, Min Sheng N. Rd.,Kweishan Hsiang,Taoyuan Hsien,Taiwan

TEL: 886-3-2121122 / FAX: 886-3-2121560

工廠：深圳市寶安區福永鎮白石廈中核集團B棟
 Factory: Block B, Nuclear Group industrial Distric
 Baishixia, Fuyung Town, Bao'an, Shenzhen, Chin:
 TEL: 86-755-27307512, 27307515
 FAX: 86-755-27308049

工廠：中國廣東省東莞市塘廈鎮林村西湖工業區
 Factory: Lin Village, Xi-Hu Industrial Area,
 Dong-guan City, Guang-Dong, China
 TEL: 86-769-87934928
 FAX: 86-769-87930899

SHENZHEN ENG ELECTRONICS CO., LTD.

FILE NO.:EN-RDS-Y193

FILE: @3A-242WU24-020

SHEET: 01

1. Product characteristics

1.1 General Description

Model 3A-242WU24 is a universal switching-mode power supply, operating at input voltage 90VAC to 264VAC and output voltage of 24VDC with 1.0A DC load

1.2 Electric Characteristics

1.2.1 Input

No	ITEM	SPECIFICATION
1.	Rated input Voltage	AC100V-240V
	Vibration input Voltage Range	AC90V-264V
2.	Frequency Rated	50-60Hz
	Frequency Vibration	47-63Hz
3.	Input Rated Current	800mA RMS Max
	Inrush Current	No damage at 230 vac Cool start
4.	Leakage current	0.25mA
5	Efficiency	82.1% Min CEC Level V
6.	Input power(no load)	<0.3W CEC Compliant

SHENZHEN ENG ELECTRONICS CO., LTD.

FILE NO.: EN-RDS-Y193

FILE: @3A-242WU24-020

SHEET: 02

1.2.2:Output:

No	ITEM	SPECIFICATION	
1.	Output voltage	24VDC	
2.	Output max. current	1.0A	
3.	Output min. Current	0A	
4.	Line regulation	± 1%	
5.	Output voltage tolerance	±5%	
6.	Short circuit protection	Output shut down and auto restart	
7.	Ripple voltage	240mV(p-p)	Input :(100V-240VAC)
			Output:Full load

Note: Ripples shall be measured with a 10uF electrolytic capacitor paralleled with a high-frequency 0.1uF ceramic capacitor across the output. The oscilloscope's bandwidth shall be set to 20MHz.

1.2.3 HI-POT SPECIFICATION

Input to output : 3000VAC or 4242VDC 10mA 1 minute.

1.2.4 Insulation resistance:

Input to output: 500Vdc to test the input to output resistance not be less 100M Ohm

1.2.5 Safety : PSE

1.2.6 EMI standard: Meet VCCI CLASS II

1.2.7 PB-free standard:RoHS Compliant

SHENZHEN ENG ELECTRONICS CO., LTD.

FILE NO.: EN-RDS-Y193

FILE: @3A-242WU24-020

SHEET: 03

1.3 Mechanical characteristics

1.3.1 AC Plug: UL

1.3.2 DC cord:

(1) Bending test: Life 1000 times 100% guarantee. Swings 120 from

Left to right loading weight 200g , 40 cycle/minute.

(2) Pull test : DC cord and plug ,weight 6kg for 1 minute.

1.3.3 Cord length and output plug: See Reference Att.4

1.3.4 Weight : 150 g

1.3.5 Case Size: (L)80 X (W)53.6X (H)35mm

1.3.6 Normal operating temperature and humidity

1.3.7 Temperature

Operating: 0 °C to 40°C

Storage : -10°C to 70°C

1.3.8 Humidity

Operating : 20% to 80%.

Storage: 10% to 90%

2.Attachment:

(Att.1) Label

(Att.2) Outdrawing

(Att.3) Package

(Att.4) Package flow chart

(Att.5) Dc cord drawing

Att.1

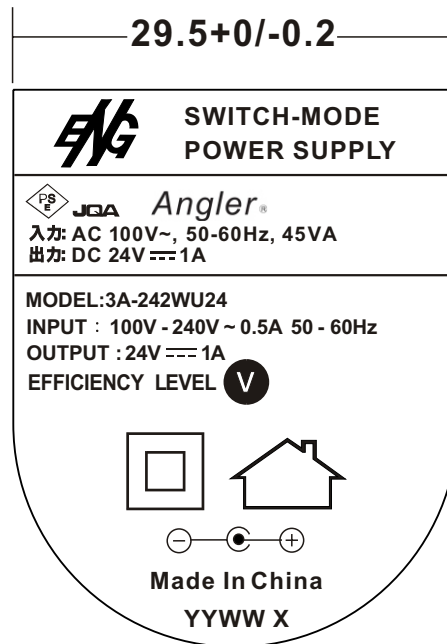

R11.5

UNIT: mm

Material: 100#PP SYNTHETIC PAPER+PP1BZ

○ BLACK WORD ON WHITE BASE

● WHITE WORD ON BLACK BASE

***@3A-242WU24-020**

TOLERANCE				

DESIGNED	CHECKED	APPROVED	TITLE		DATE
Dragon	Chen Mgr	Bill	LABEL		9/23-09
			UNITS	mm	DRAWING No.
			SCALE	2:1	@N20-WW7300-A12
SHENZHEN ENG ELECTRONICS CO., LTD.			DRAWING NAME		REVISION
			122301 LABEL		01

Att.2

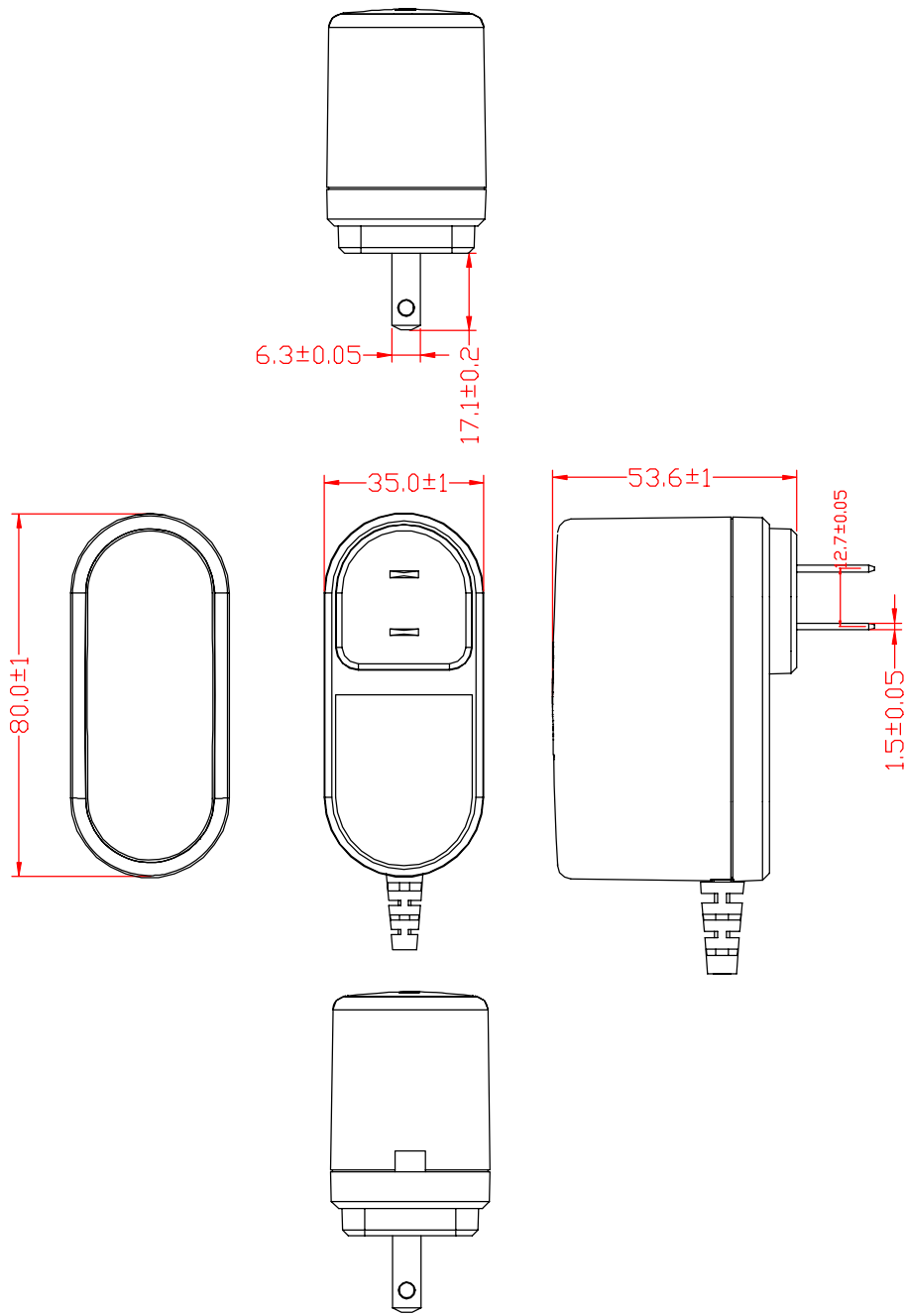

TOLERANCE				

DESIGNED	CHECKED	APPROVED		TITLE	DATE
Dragon	Chen Mgr	Bill		UNITS	OUTDRAWING
				SCALE	
SHENZHEN ENG ELECTRONICS CO., LTD.				DRAWING No.	REVISION
				122300/01	01
				DRAWING NAME	
				UL CASE	

RDS-041 07.03

Att.3

CARTON SIZE: 435X395X178mm

外箱尺寸 435X395X178mm

Q' TY: 80pcs(20x4)

数量 80pcs(20x4)

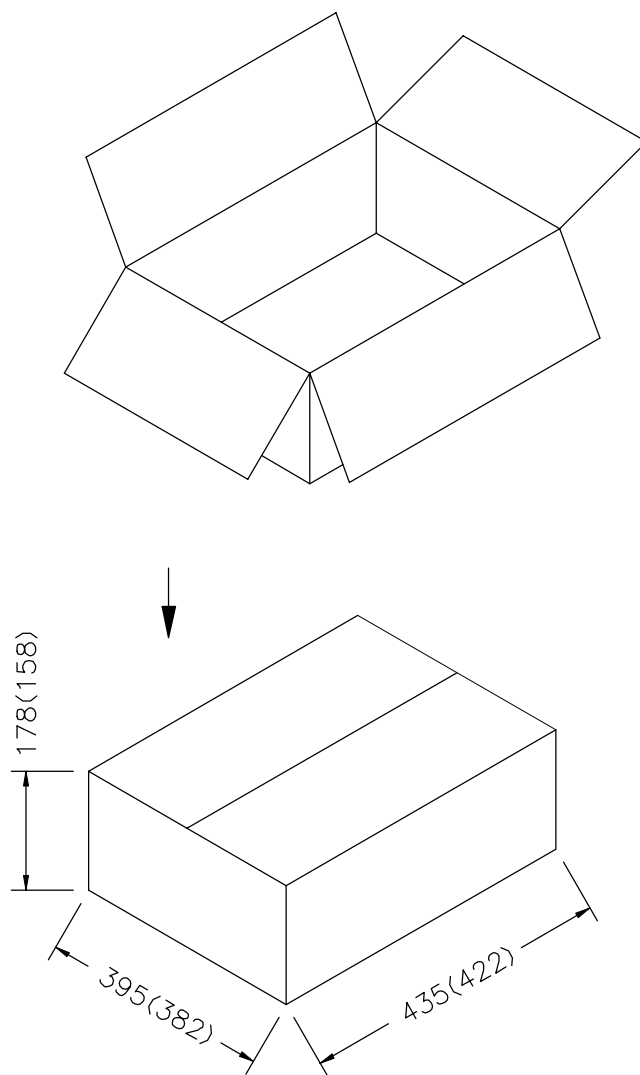

The tolerance of the internal dimensions of the carton is +7/-0

紙箱內度尺寸公差為 +7/-0

TOLERANCE				

DESIGNED	CHECKED	APPROVED			TITLE	DATE
Hump	ZhoujgBill		UNITS	mm	PACKAGE	07/08/28
			SCALE		DRAWING No. PS0-2040-H-50	
SHENZHEN ENG ELECTRONICS CO., LTD.					DRAWING NAME S0-2040-H-50	REVISION 01

Att.3.1

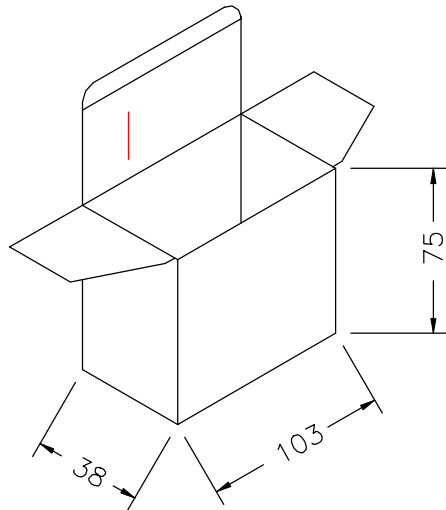
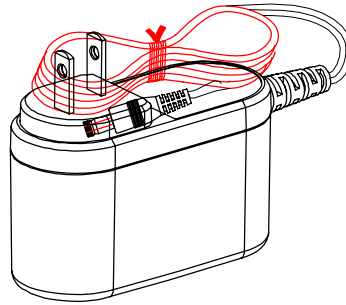

← White Box: NO.280

The tolerance of the external dimensions of the white box is ± 1
 小禮盒外度尺寸公差為 ± 1

TOLERANCE				

DESIGNED	CHECKED	APPROVED			TITLE	DATE
Hump	Zhoujg	Bill	UNITS	mm	PACKAGE FLOW CHART	07/08/28
SHENZHEN ENG ELECTRONICS CO., LTD			SCALE		DRAWING No.	REVISION
					280# 1223	01
					DRAWING NAME	
					1223 Box Package	

Att.4

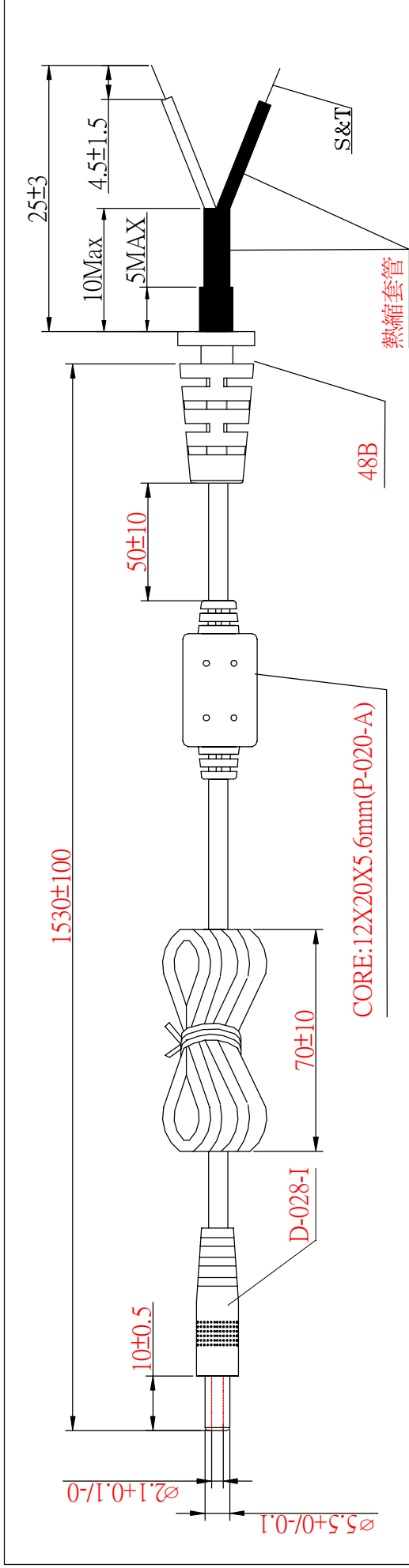

#20AWG 1C+SHIELDUL1185 SHIELD WIRE IN OUTER, WHITE WIRE IN INNER
 (白線接內，屏蔽線接外)。OD: $\varnothing 3.0$

TOLERANCE	

DESIGNED	CHECKED	APPROVED	TITLE	DATE
Zeng XQ	Liu M	Zhu RG	DC CORD	5/14-09
UNITS			DRAWING No.	REVISION
SCALE			D45-48B028-03A-01	01
SHENZHEN ENG ELECTRONICS CO., LTD.			DRAWING NAME	
			@3A-242WUXX WW73 DC CORD	

VIBRATION TEST	Parameter request
	a. $\pm 60^\circ$ b. WEIGHT 200g c. 40 ROUND/MINUTE d. OVER 1000 COUNT MIN